



INTERNATIONAL APPLICATION PUBLISHED UNDER THE PATENT COOPERATION TREATY (PCT)

<p>(51) International Patent Classification ⁵ : G06G 9/04, H01H 25/00</p>	<p>A1</p>	<p>(11) International Publication Number: WO 93/18475 (43) International Publication Date: 16 September 1993 (16.09.93)</p>
<p>(21) International Application Number: PCT/US93/01842 (22) International Filing Date: 1 March 1993 (01.03.93) (30) Priority data: 07/847,619 5 March 1992 (05.03.92) US (71)(72) Applicant and Inventor: ARMSTRONG, Brad, Alan [US/US]; 6630 Arabian Circle, Roseville, CA 95661 (US). (74) Agents: ST. JOHN, Richard, J. et al.; West 601 Main Avenue, Suite 815, Spokane, WA 99201-0679 (US). (81) Designated States: AT, AU, BB, BG, BR, CA, CH, CZ, DE, DK, ES, FI, GB, HU, JP, KP, KR, KZ, LK, LU, MG, MN, MW, NL, NO, NZ, PL, PT, RO, RU, SD, SE, SK, UA, European patent (AT, BE, CH, DE, DK, ES, FR, GB, GR, IE, IT, LU, MC, NL, PT, SE), OAPI pa- tent (BF, BJ, CF, CG, CI, CM, GA, GN, ML, MR, SN, TD, TG).</p>		<p>Published <i>With international search report. Before the expiration of the time limit for amending the claims and to be republished in the event of the receipt of amendments.</i></p>

(54) Title: SIX DEGREES OF FREEDOM CONTROLLER WITH TACTILE FEEDBACK

(57) Abstract

Described and shown is a six degree of freedom physical to electrical converter with capability of tactile feedback, or more specifically, a human hand operated input controller with the capability of vibration feedback in the handle. Multiple embodiments, each capable of translating complex three dimensional linear and rotational forces into their constituent orthogonal vectors are described and shown. Also described and shown are various different sensor types which can be implemented in the embodiments. The embodiments have physical space between sensors and actuators maintained by resilient means, enabling tactile feedback (vibration) to be induced directly in the handle without erroneously activating sensors.

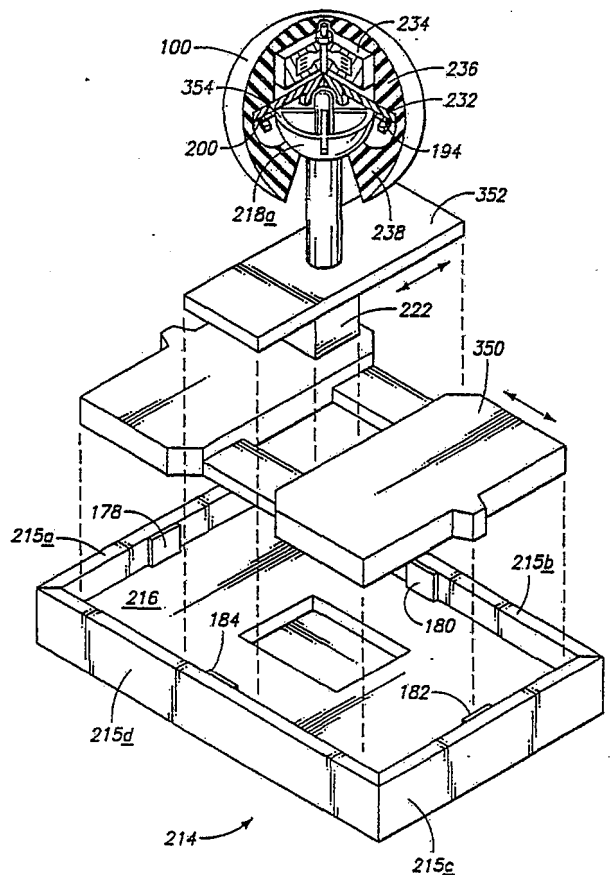

FOR THE PURPOSES OF INFORMATION ONLY

Codes used to identify States party to the PCT on the front pages of pamphlets publishing international applications under the PCT.

AT	Austria	FR	France	MR	Mauritania
AU	Australia	GA	Gabon	MW	Malawi
BB	Barbados	GB	United Kingdom	NL	Netherlands
BE	Belgium	GN	Guinea	NO	Norway
BF	Burkina Faso	GR	Greece	NZ	New Zealand
BG	Bulgaria	HU	Hungary	PL	Poland
BJ	Benin	IE	Ireland	PT	Portugal
BR	Brazil	IT	Italy	RO	Romania
CA	Canada	JP	Japan	RU	Russian Federation
CF	Central African Republic	KP	Democratic People's Republic of Korea	SD	Sudan
CG	Congo	KR	Republic of Korea	SE	Sweden
CH	Switzerland	KZ	Kazakhstan	SK	Slovak Republic
CI	Côte d'Ivoire	LJ	Liechtenstein	SN	Senegal
CM	Cameroon	LK	Sri Lanka	SU	Soviet Union
CS	Czechoslovakia	LU	Luxembourg	TD	Chad
CZ	Czech Republic	MC	Monaco	TG	Togo
DE	Germany	MG	Madagascar	UA	Ukraine
DK	Denmark	ML	Mali	US	United States of America
ES	Spain	MN	Mongolia	VN	Viet Nam
FI	Finland				

DESCRIPTION**SIX DEGREES OF FREEDOM CONTROLLER WITH TACTILE FEEDBACK****Technical Field**

This invention relates to an interactive computer device having six degrees
5 of freedom input and tactile feedback output, specifically, an interactive computer
device to be operated by the human hand.

Background Art

A variety of controllers having six degrees of freedom (hereinafter "6-
DOF") have been described in the prior art.

10 In large part, the prior art has been dedicated to feedback mechanisms
for robotic arms. Work done in this field, such as U.S. Patent No. 3,693,425
to Starita and Macosko, U.S. Patent No. 4,369,663 to Venturello et al., U.S.
Patent No. 4,099,409 to Edmond, and U.S. Patent No. 3,921,445 to Hill et al.,
falls short of the optimum as a hand operated device. Robotic sensors need to
15 be highly precise, allowing no unresponsive play of actuator mechanisms. On the
contrary, a human hand input device optimally has built-in tolerance to allow for
tactile feedback vibrations and to compensate for imprecisions of the human
hand. The prior art falls short on these considerations and on basic
considerations such as sensor cross-talk, thermal stability, computational overhead,
20 excessive electronic arbitration of sensors, and economy of manufacture.

A number of prior art inventions relate to determining signature
verification, such as U.S. Patent No. 4,536,746 to Gobeli. Prior art of this type
is generally insufficient for the above stated reasons and for its lack of full 6-
DOF capability.

25 Prior art devices of a "joystick" type of hand operated controllers such as
U.S. Patent No. 4,297,542 to Shumway, and U.S. Patent No. 4,684,089 to van
der Lely are also insufficient for the above stated reasons, specifically this art
lacks true 6-DOF capability and tactile feedback capability.

Other commonly available prior art devices such as the Mouse, the Track
30 Ball, and the Touch Screen are all 2D input device incapable of 6-DOF input
necessary for control in a 3D environment.

Prior art devices using a polhemus sensor, including the data glove, U.S.
Patent No. 4,414,537, fall short of the optimum for hand operated controllers in
that they are absolute position devices. Such devices require a large range of
35 physical world movement which is undesirable for this kind of interactive device

because of two main deficiencies. First, users of these devices complain of a "tired-arm" syndrome, which results from the necessity of holding one's hand (or an object containing the polhemus sensor) in an elevated position for prolonged periods. Second, the virtual environment with which the user is interacting does not have the physical limitations of the real world, thus the operator's hand may conflict with real world objects and limitations that do not exist in the virtual environment. A third deficiency, specific to the data glove, is that it requires immense and unnecessary software complexity.

An additional work of prior art is the Dimension-6 line of computer controllers as marketed by CIS Graphics of Westford, MA. These devices, while having a full 6-DOF capability, have no capacity for the incorporation of vibration as tactile feedback. These devices are dependent on optical sensors, and vibration of the handle will create a wildly fluctuating output signal. Further, with no sensor isolation, these devices suffer from sensor cross-talk, making them unforgiving to the imprecisions of human hand input.

It will be seen in the objects and advantages of the current art that the above weaknesses of the prior art are entirely overcome.

Disclosure of Invention

In order for a user to intuitively manipulate objects and/or navigate a viewpoint within a three-dimensional Virtual Reality, it is necessary to directly translate natural physical stimuli into similar virtual "action".

A primary object of this invention is to provide means of inputting commands with six degrees of freedom while providing the advantage of tactile feedback to the user. Such feedback could be employed, for example, in the case that the user attempts to pass through a blockage or make some other illegal movement input. In the real world, if a person touches one object with another, he or she senses the physical contact with his or her hand. With this invention, when movement results in "contact", the ball gently vibrates. The mind naturally interprets this vibration as normal tactile feedback, thus this invention offers a rich natural interaction with the electronic environment.

Another object of this invention is to provide means of inputting commands with six degrees of freedom while providing the advantage of having spatial sensor isolation. Such isolation is a definite advantage in that it eliminates error from vibration and from inaccurate human input. Unlike in the prior art, the sensor isolation of this invention allows the advantage that the

handle can vibrate for tactile feedback without producing any unwanted signals. Also unlike in the prior art, the sensor isolation of this invention allows tolerance that forgives the imprecisions of human-hand input.

Another object of this invention is to provide means of mechanically
5 translating full 6-DOF physical real-world motion directly into electrical outputs. Since each sensor of these teachings is directly associated with exactly one of twelve orthogonal outputs, no additional circuitry or computational power is required to resolve signals into vector components.

Additionally, this invention provides the advantage of sensor independence.
10 Unlike the prior art, this invention is an input device that has physical manifestations that can stimulate any of various types of sensors. While the prior art is dependent upon specific types of sensors, this invention can be constructed with sensors as inexpensive as simple electrical contacts or as sophisticated as a manufacturer desires.

15 Another advantage of this invention is with regard to its economy of manufacture. Traditionally, three-dimensional graphics computers have not been price sensitive, but the price is rapidly falling and will soon be an important consideration. The physical structure of this invention can be manufactured for
only a very minimal cost in injection-molded parts.

20 Another object of this invention is to provide means of inputting commands with six degrees of freedom while providing the advantage of intuitive input. This invention directly translates natural physical stimuli into similar virtual "action". Fortunately, since we live in a three-dimensional world, natural movements serve well as direct commands. For example, to rotate clockwise a
25 selected object, one must simply apply clockwise pressure to the handle. All commands are equally intuitive and easy to use.

Another object of this invention is to provide means of inputting
commands with six degrees of freedom while providing the advantage of a
stationary input position for the user. Unlike the prior art, such as devices
30 using the polhemus sensor (e.g., the data glove), which are absolute position devices, the current invention is a relative position device. A relative position device has many advantages over an absolute position device. Six degree of freedom input devices are often controllers of a virtual or imaginary electronic world. These virtual worlds can be likened to dream worlds of unlimited scope.
35 An operator in these virtual worlds still exists in a real world with physical

limitations. Just like when someone is in a dream and the brain turns off all motor activity so that the dreamer does not conflict with the physical limits of the real world, it is important also for someone in a virtual world to have no conflict with the physical limitations of the real world. Unlike absolute
5 positioning devices which require a large range of real world movement to control the virtual world, this invention requires minimal real world movement. An additional benefit of this advantage is that the hand and arm of the user remain in a comfortable and rested position during operation. This is in marked contrast to an absolute position device such as the data glove in which the
10 operators arm becomes quickly fatigued from movement and the necessity of maintaining the user's hand in an elevated position.

Another object of this invention is to provide means of inputting commands with six degrees of freedom while providing the advantage of versatility of complex movements. This invention is fully featured. all three perpendicular
15 Cartesian coordinates are interpreted bidirectionally, as are the rotations about each axis. These linear and rotational vectors can be combined in every possible way. This feature of all possible vector combinations allows this invention to describe every possible motion in three dimensions.

Another object of this invention is to provide hand-operated control means
20 for physical, real-world machines, such as forklifts, aircraft, spacecraft, etc.

Further objects and advantages of this invention will become evident upon consideration of the following descriptions and drawings.

Brief Description of the Drawings

Preferred embodiments of the invention are described below with reference
25 to the following accompanying drawings.

Fig. 1 is a partially exploded perspective view showing the preferred embodiment.

Fig. 2 shows a median section view of the preferred embodiment.

Figs. 3A and 3B show a horizontal section view taken through line 3-3
30 of Fig. 2.

Figs. 4A and 4B show a perspective view of two different locations for placement of turn left and right sensors.

Figs. 5A and 5B show partially exploded views of alternate sliding plates actuator assemblies for the preferred embodiment.

35 Fig. 6 shows a perspective view of a second embodiment.

Fig. 7 shows a section view of the second embodiment taken through line 7-7 of Fig. 6.

Fig. 8 shows a section view of the second embodiment taken through line 8-8 of Fig. 7.

5 Fig. 9 shows a median section view of an inverted hemisphere embodiment having a mechanical pivot arrangement.

Figs. 10A, 10B and 10C show a very simple, reliable contact sensor.

Figs. 11A, 11B, 11C, 11D, 11E, 11F, 11G, and 11H show some sensor types that are possible for use in the current art.

10 Best Modes for Carrying Out the Invention

Figs. 1, 2, 3A, and 3B show the preferred embodiment of this invention, which is a twelve-sensor device. Each sensor is distinctly associated with a single orthogonal output vector. In Fig. 1, a base assembly 214 is shown for clarity without a top. Base assembly 214 is shown as an essentially rectangular structure showing forward wall 215a, a right wall 215b, a rear wall 215c, and a left wall 215d; however, base assembly 214 is in no way limited to being rectangular in shape. Inside base assembly 214 is shown a retaining shelf 216 which is positioned essentially on a horizontal plane.

In the vicinity of and essentially centered along the length of forward wall 20 215a is a move forward sensor 178. In the vicinity of right wall 215b is a move right sensor 180. In the vicinity of and essentially centered along the length of rear wall 215c is a move back sensor 182. In the vicinity of left wall 215d is a move left sensor 184.

Sliding-plate-linear-conversion means is sandwiched between retaining shelf 25 216 and top of the base assembly 215e, here shown as a sliding actuator plates assembly 348 comprising two pieces of which the larger piece is a greater sliding plate actuator 350, which has within it a recess into which fits a lesser sliding plate actuator 352.

The shape of sliding-plate-linear-conversion means is not limited to the 30 specific shape described above, but can be quite diverse, as will be shown later in this teaching. Sliding actuator plates assembly 348 is suspended in a position neutral to and spatially separated from sensors 178 through 184, thus providing excellent sensor isolation from any cross-talk, vibration, or other undesired input. In order to be as friction-free as possible sliding actuator plates assembly 348 35 may be made of very low surface-resistance material, such as Teflon or other

materials having similar characteristics. The material means for low surface-resistance may also be applied as tape, runners, or feet for sliding actuator plates assembly 348. The low surface-resistance material means may also be applied to retaining shelf 216, and similar means may be applied to the bottom surface of top of the base assembly 214.

At the approximate center of lesser sliding plate actuator 352 is an aperture 360 through which passes vertically a shaft 102.

Shaft 102 extends below the sliding actuator plates assembly 348 into a lower-shaft means subassembly 222, which is fixed to the lower side of lesser sliding plate actuator 352. Subassembly 222 comprises means for support of a rigidly fixed lower shaft guide 224, a move up sensor 186, a move down sensor 188, and a shaft actuator tab 252 centered with space between move up sensor 186 and move down sensor 188. A variation of this embodiment within the scope of the lower-shaft means has shaft 102 rotationally fixed within handle 100 as shown in Figs. 3A and 4A. Shaft 102 is free to turn within aperture 360 of lesser sliding plate 352. Turn left sensor 192 and turn right sensor 190 are located within subassembly 222 at opposing sides of shaft actuator tab 252 as indicated by Figs. 3B and 4B. One skilled in the art will recognize many obvious variations possible within the scope of lower-shaft means. Combining the above described sliding-plate-linear-conversion means and lower-shaft-conversion means results in a fully featured base-linear-conversion means.

A base assembly floor 217 is removably attached to the bottom of base assembly 214. As most of these parts will likely be injection molded, they will probably not exhibit only the simple functionality shown here. For example, the base assembly floor 217 may actually be produced as the whole lower half, or even more, of base assembly 214. Top of the base assembly 215e, which functions as means prohibiting the sliding plate actuators from upward vertical movement, may be realized as a simple functional structure, for example distending feet, that are not the actual top of base assembly 215e.

The upper end of shaft 102 is fixed to a partial spherical section 218, specifically, but not limited to a lower partial sphere 218a. Protruding from lower partial sphere 218a, near the plane of the horizontal equator, as shown clearly in Figs. 3A and 3B, are four circular actuator support attachments 356, extending orthogonally outward. Fixed to the support attachments 356 is a circular actuator 354. Protruding on opposite sides from circular actuator 354

are two turn-stop tabs 242 which are confined by four turn-stop posts 245 that are fixed within the ball-shaped handle 100 as shown in Fig. 3A. Fig. 3B shows a variation having one turn-stop tab 242 that is not so closely constricted by turn-stop posts 245. In place of the second turn-stop tab 242, is a turn-stop actuator 242a having turn left sensor 192 and turn right sensor 190 located to each side of turn-stop actuator 242a and fixed within handle 100.

Pivotal-conversion means is illustrated in Figs. 2, 3A, and 3B. As shown in Fig. 2, a male pivot protrusion 246 is fixed centrally to and rises vertically in the lower partial sphere 218a and ends at substantially the plane of the horizontal equator of the lower partial sphere 218a. A female pivot receptacle 248 rests upon male pivot protrusion 246 and is an integral part of an upper platform 232. As shown in Figs. 3A and 3B, four sensors 194, 196, 198, and 200, are fixed about the upper platform 232 and positioned horizontally and orthogonally in such a way as to be each one above circular actuator 354.

Upper platform 232 attaches in a fixed manner to the inside of handle upper hemisphere 236. An optional tactile feedback means 234, such as a small electric motor with an offset weight on its shaft, can be fixed either to upper platform 232 or to the inside of handle upper hemisphere 236. Handle upper hemisphere 236 comprises a centrally located upper cavity of sufficient volume for containing tactile feedback means 234 and for allowing free rotation of the offset weight. A partial handle lower hemisphere 238 is fixed to, or integrally formed with, handle upper hemisphere 236 in such a way as to form a ball-shaped handle 100. Partial handle lower hemisphere 238 would be a complete lower hemisphere, except for a conical or otherwise-shaped section removed from the lowest point to allow limited rotational movement of ball-shaped handle 100 in freedom from obstruction by shaft 102c. On the inside of lower partial sphere 238 and immediately above the removed conical section is a partial inverse-sphere guide 240, which has only a slightly larger radius than the outside of lower partial sphere 218a.

Operationally speaking, one skilled in the art will recognize that this is a device for inputting six degrees of freedom which can be described by six mathematical vectors. One vector for each of the three linear cartesian coordinates, and another vector for a rotation about each axis, adding up to six vectors. Every vector can be either positive or negative, that is travel can be in either direction along the vector. In a practical sense, this doubles the

number into twelve common everyday outputs: MOVE forward or backward, left or right, up or down; and TURN left or right, up or down, and clockwise or counter-clockwise. The entire scope of movement in three dimensions is defined by these and combinations of these twelve outputs. All physically possible
5 combinations of outputs are achievable by the designs of these teachings. However, in the interest of clarity, the following summary of outputs will deal only with the specific physical stimulations that cause single sensor outputs.

A linear force applied by a hand to handle 100 is transferred directly to shaft 102. If the linear force is applied in a forward, right, backward, or left
10 direction (i.e., a horizontal linear force), then the force is directly transferred from shaft 102 to sliding actuator plates assembly 348, causing either greater sliding plate actuator 350 or lesser sliding plate actuator 352 to move along the direction of the force to cultivate the appropriate sensor 178, 180, 182, or 184. If the linear force is applied either upwardly or downwardly (i.e., a vertical
15 linear force), then the force directly causes shaft 102 to pass freely through aperture 360 in sliding plates assembly 348, along the direction of the force, thus causing shaft actuator tab 252 to activate the appropriate sensor 186 or 188.

Assuming a standard x, y, z coordinate system, a rotational force applied by a hand to the handle 100 in either direction around the vertical y-axis (i.e.,
20 turn left or turn right) slightly rotates handle 100. This rotation moves the appropriate sensors 190 or 192 into contact with turn-stop actuator 242a distending from circular actuator 354. A rotational force applied by hand to handle 100 in either direction around the horizontal x- or z-axis (i.e., turn up, turn down, clockwise, counter-clockwise) causes handle 100 to rotate about the
25 same axis as the force. Sensors 194, 196, 198, or 200, fixed inside handle 100, are activated by substantially stationary circular actuator 354.

Figs. 4A, 4B, and 6 show possible positions for sensors 190, 192 relative to shaft 102. Specifically, Fig. 4A shows shaft 102 having a shaft actuator tab 252 with turn right and turn left sensors 190 and 192 located within base
30 assembly 214. Fig. 4B shows a square shaft 102c or any shaft 100 that is rotationally fixed within base assembly 214, with turn right and left sensors 190, 192 being located about partial hemisphere 218a to each side of turn stop actuators 242a. Fig. 6 shows sensors 190 and 192 positioned adjacent platform 205, which is integrally formed with shaft 102c.

Sensors 190 and 192 interpret rotational forces around shaft 102 and thus can be located in numerous locations. Such configurations provide shaft-rotational-conversion means with sensors located directly about shaft 102 (Fig. 4A), about a platform such as a sliding platform 205 (Fig. 6), about the
 5 outer rim of lower partial sphere 218a (Fig. 4B), or other conceivable arrangements. The full range of all possible rotations transduced by this invention are termed rotational-conversion means which comprises shaft-rotational-conversion means and pivotal-conversion means.

Figs. 5A and 5B show perspective views of some possible arrangements
 10 of sliding-plate-linear-conversion means, specifically two different designs for the sliding actuator plates assembly 348. Fig. 5A shows a tongue-in-groove type of embodiment where lesser sliding plate actuator 352 has two protruding tongue-like structures, one along each of its longer sides, which ride within grooves in greater sliding plate actuator 350. Greater sliding plate actuator 350 also has
 15 tongue-like structures along its sides that are perpendicular to those on lesser sliding plate actuator 352 which fit into groove type fittings that would reside in or be integral parts of base assembly 214. Fig. 5B shows the direction of travel of greater sliding plate actuator 350 and lesser sliding plate actuator 352 being reversed in direction but still equally functional. In this embodiment, the
 20 greater and lesser sliding plate actuators have sliding means comprising dovetail type arrangements 350m and 352m. This serves to emphasize the large number of potential variations on this theme. Additional examples might have lesser sliding plate 352 in a recess on the lower side of greater sliding plate 350 instead of on the upper side.

25 Figs. 6, 7 and 8 show another embodiment of this invention, which is a twelve-sensor device. Each sensor is distinctly associated with a single orthogonal output vector. In Fig. 6, base assembly 214 is shown without a top. Base assembly 214 is shown as an essentially rectangular structure having suction cup mounts 212 at the bottom corners. However, base assembly 214 is in no way
 30 limited to being rectangular in shape. Inside base assembly 214 is shown as a retaining shelf 216. Above retaining shelf 216 are positioned six sensors. In the vicinity of and essentially centered along the length of forward wall 215a is move forward sensor 178. In the vicinity of right wall 215b is move right sensor 180. In the vicinity of and essentially centered along the length of rear
 35 wall 215c is move back sensor 182. In the vicinity of the left wall 215d is

move left sensor 184. Essentially facing each other and substantially perpendicular to move back sensor 182 are positioned turn right sensor 190 and turn left sensor 192.

Sliding platform 205 is shown as an essentially large square-like structure with rounded corners, having a similarly shaped but smaller structure protruding from its rear corner. The shape of sliding platform 205 is not limited to the specific shape described above, but can be quite diverse, as will be shown later in this teaching. Sliding platform 205 is suspended in a position neutral to and spatially separated from sensors 178, 180, 182, 184, 190, and 192, thus providing excellent sensor isolation from any cross-talk, vibration, or other undesired input. The suspension of sliding platform 205 is accomplished by retaining shelf 216 and four tension springs 177a. In order to be as friction-free as possible, sliding platform 205 may be made of very low surface-resistance material, such as Teflon or other materials having similar characteristics. The material means for low surface-resistance may also be applied as tape, runners, or feet for sliding platform 205. The low surface-resistance material means may also be applied to retaining shelf 216, and similar means may be applied to the bottom surface of the top of base assembly 214.

Tension springs 177a are connected to the sides of sliding platform 205 essentially at the midpoints of each side. Tension springs 177a extend radially and are connected to four spring mounts 210a located on base assembly 214. Tension springs 177a perform a function that can be accomplished by other means, comprising the use of rubber, foam, or other resilient materials.

At the approximate center of sliding platform 205 is a square-shaped aperture through which passes vertically a square shaft 102c. One skilled in the art will easily recognize that square shaft 102c is not the only means for transferring rotational forces from shaft 102 to sliding platform 205, thus shaft 102 is not necessarily square-shaped.

As shown in Fig. 7, square shaft 102c extends below the sliding platform 205 into subassembly 222, which is fixed to the lower side of sliding platform 205. Subassembly 222 comprises means for support of a rigidly fixed lower shaft guide 224, move up sensor 186, move down sensor 188, and shaft actuator tab 252. Resilient means keep shaft actuator tab 252 centered with space between move up sensor 186 and move down sensor 188.

Base assembly floor 217 is removably attached to the bottom of base assembly 214, creating an enclosure in which interfacing circuitry 213 may be mounted.

The upper end of shaft 102c is fixed to partial spherical section 218, specifically, but not limited to lower partial sphere 218a. Protruding from lower partial sphere 218a, in the plane of the horizontal equator, are four actuator tabs 220a, 220b, 220c, and 220d, extending orthogonally outward (Fig. 8). Actuator tab 220a is located in a forward position, actuator 220b is located in a right position, actuator 220c is located in a rear position, and actuator 220d is located in a left position. Integrally formed with actuator tabs 220 are two semi-annular turn-stop ears 244, with recesses midway between actuator tabs 220. Turn-stop ears 244 extend outward from lower partial sphere 218a in the plane of its horizontal equator.

Fixed centrally to and rising vertically in lower partial sphere 218a is a lower pivot-spring cylinder 226 which ends at substantially the plane of the horizontal equator of lower partial sphere 218a. A sturdy pivot-spring 228 fits firmly into pivot-spring cylinder 226 and extends substantially above the end of pivot-spring cylinder 226. Pivot-spring 228 extends upward, fitting firmly into an upper pivot-spring cylinder 230 which is an integral part of upper platform 232. Fixed to upper platform 232 are four sensors, namely turn up sensor 194 positioned directly above the rear actuator 220c, turn down sensor 196 positioned directly above forward actuator tab 220a, turn clockwise sensor 198 positioned directly above right actuator tab 220b, and turn counter-clockwise sensor 200 positioned directly above left actuator tab 220d.

Upper platform 232 attaches in a fixed manner to the inside of handle upper hemisphere 236. A tactile feedback means 234, such as a small electric motor with an offset weight on its shaft, can be fixed to upper platform 232 or to the inside of handle upper hemisphere 236. Handle upper hemisphere 236 comprises a centrally located upper cavity of sufficient volume for containing tactile feedback means 234, namely a small electric motor with an offset weight on its shaft, and for allowing free rotation of the offset weight. A partial handle hemisphere 238 is fixed to, or integrally formed with, handle upper hemisphere 236 in such a way as to form ball-shaped handle 100. Lower partial sphere 238 would be a complete lower partial sphere, except for a conical section removed from the lowest point of a lower partial sphere, thus allowing

limited rotational movement of ball-shaped handle 100 in relation to square shaft 102c. On the inside of partial handle lower hemisphere 238 and immediately above the removed conical section is a partial inverse-sphere guide 240, which has substantially the same radius as the outside of lower partial sphere 218a.

5 On the inside of handle lower hemisphere 238 and immediately above partial inverse-sphere guide 240 are four tab cavities, each associated with the area in which an actuator tab 220 resides, thus allowing free movement of actuator tabs 220. In between opposite two of the four tab cavities are ear cavities of similar vertical depth to the tab cavities, but having a smaller radius from the

10 center of handle lower hemisphere 238. In the center of each ear cavity rises a turn-stop tab 242, which fits firmly between two turn-stop ears 244.

Operationally speaking, a linear force applied by a hand to the handle 100 is transferred directly to the square shaft 102c. If the linear force is applied in a forward, right, backward, or left direction (i.e., a horizontal linear force),

15 then the force is directly transferred from square shaft 102c to sliding platform 205, causing sliding platform 205 to move along the direction of the force to activate appropriate sensors 178, 180, 182, or 184. If the linear force is applied either upwardly or downwardly (i.e., a vertical linear force), then the force directly causes shaft 102c to pass freely through the aperture in sliding-platform

20 205, along the direction of the force, thus causing shaft actuator tab 252 to activate the appropriate sensor 186 or 188.

Assuming a standard x, y, z coordinate system, a rotational force applied by hand to handle 100 in either direction around the vertical y-axis (i.e., turn left or turn right) is transferred from handle 100 through turn-stop tabs 242,

25 through turn-stop ears 244, through lower partial sphere 218a, and through square shaft 102c, to sliding platform 205, thus causing sliding platform 205 to rotate and the smaller structure protruding from its rear corner to activate the appropriate sensor 190 or 192. A rotational force applied by a hand to handle 100 in either direction around the horizontal x- or z-axis (i.e., turn up,

30 turn down, clockwise, counter-clockwise), causes handle 100 to rotate about the same axis as the force. A sensor 194, 196, 198, or 200, fixed inside moveable handle 100, is activated by substantially stationary actuator tab 220c, 220a, 220b, or 220d respectively.

Fig. 9 shows an embodiment that has similarities to the preferred

35 embodiments. The hemispherical assembly in the base of Fig. 9 is an inversion

of that in the handle of the preferred embodiments, with sensor placements optionally either above or below actuator tabs 220. Instead of sliding platform 205, the design of Fig. 9 incorporates an actuator enclosure 254 that moves in a horizontal plane to activate sensors 178, 180, 182, 184, as shown in
5 and described as the preferred embodiment in Figs. 1 and 2. Actuator enclosure 254 is not limited to being of square shape, but it can be any of a great diversity of forms as will be obvious to one skilled in the art. In the lower portion of base assembly 214 is shown space sufficient for the containment of electronic interfacing circuitry.

10 Figs. 10A, 10B, and 10C show an exceptionally simple, economical, durable and electrically clean sensor switch comprised of a circuit board 400, electrical traces 402, and a switch member 404. Switch member 404 is a concave-shaped piece of springy conductive metal having dimpled feet and a dimpled central contact. It is held down to the circuit board by an over laying of adhesive
15 tape. Traces 402 are etched in a pattern as to fit under the dimpled feet and dimpled central contact of switch member 404. This sensor was observed in a Radio Shack 2D joystick covered only by a design patent showing the outer shape of the joystick handle so this sensor is presumably in the public domain.

Fig. 11 shows some sensor types that are possible for use in the current
20 art. Shown are a simple electrical contact sensor, a simple piezo contact sensor, a piezo resistive pressure sensor as manufactured by SENSYSM, Inc., of Sunnyvale, California, a Hall Effect magnetic proximity sensor available from SPRAGUE Electric Co. of Concord, New Hampshire, an integrated capacitive sensor, a separate capacitive sensor, and a "singing technology" sensor 304 as
25 developed by Pennwalt Corp. of Valley Forge, Pennsylvania, all of which will be obvious to one skilled in the art.

Specifically, Fig. 11A shows a simple electrical contact sensor means having an electrically active activator 281 spatially separated from an electric contact surface 282 which is fixed to a sensor mount 202.

30 Shown in Fig. 11B is a simple piezo contact sensor means having an actuator 285 spatially separated from a piezo contact sensor 286 which is fixed to sensor mount 202.

Shown in Fig. 11C is a piezo resistive pressure sensor means having actuator 285 spatially separated from a piezo resistive pressure sensor 289 which
35 is fixed to sensor mount 202.

Shown in Fig. 11D is a Hall Effect magnetic proximity sensor means having a magnetic actuator 295, spatially separated by resilient means 250 from a Hall Effect magnetic proximity sensor 293 which is fixed to sensor mount 202.

Shown in Fig. 11E is a Hall Effect magnetic proximity sensor means
5 having a ferrous actuator 291, spatially separated by resilient means 250 from a Hall Effect magnetic proximity sensor 293 having a rear mounted magnet 294.

Shown in Fig. 11F is an integrated capacitive sensor means having a polarized actuator 297 spatially separated by dielectric resilient means 299 from a capacitive surface 298 fixed to sensor mount 202.

10 Shown in Fig. 11G is a separate capacitive sensor means having actuator 285 spatially separated from a compressible capacitive sensor 301 which is fixed to sensor mount 202. Compressible capacitive sensor 301 comprises two capacitive surfaces 298 separated by a dielectric resilient means 299 and enclosed by a flexible hermetically sealed wrapper 300.

15 Shown in Fig. 11H is a "singing technology" sensor 305 which is fixed to sensor mount 202 at both of its linear ends. Singing sensor 305 could be mounted from a single end. Sensors of this type are a piezo electric film sandwich with KYNAR® piezo film attached to both sides of a spring steel element, which is induced to resonate at a frequency dependent on the load
20 applied to sensor 305.

Six degree of freedom input device according to this invention enables a highly reliable, functional, and exceptionally economical device that is forgiving of human inaccuracies of the hand and precise in interpreting the user's intended input. Also with this art is the capability of tactile feedback to the hand.

25 While the above description and the accompanying figures show many specificities, these should not be construed as limiting the scope of the invention. The embodiments shown are but examples of the claimed art as one skilled in the art will see that many other variations are possible. For example, the sliding plates assembly 348 in base 214 of Figs. 1 and 2 might have the lesser
30 plate 350 below the greater plate 354 rather than above it, or subassembly 222 might reside above lesser plate 350 rather than below it as illustrated. Handle 100 pivot mechanism means and actuator means of the embodiment shown in Figs. 1, 2, and 3 are structurally completely different from those of the embodiment of Figs. 5, 6, and 7, while remaining functionally identical.
35 Handle 100 might not be ball-shaped, but rather shaped like a joystick handle.

Thus, the scope of this invention should be determined not by a strict interpretation of the shown Figures, but rather by the claims and their legal equivalents.

Claims

1. A six degree of freedom controller comprising:
a base assembly;
a handle;

5 a shaft having one end operatively mounted to the handle and a second end operatively mounted to the base assembly;

first conversion means for coupling the shaft to the handle, the first conversion means permitting rotational movement of the handle relative to the shaft and generating electrical signals indicative of the rotational movement; and

10 second conversion means for coupling the shaft to the base assembly, the second conversion means providing linear movement of the shaft relative to the base assembly and generating electrical signals indicative of the linear movement.

2. A six degree of freedom controller according to claim 1 wherein
15 the first and second conversion means comprise a plurality of sensors to detect the rotational and linear movement.

3. A six degree of freedom controller according to claim 1 wherein
the first conversion means comprises:

20 first sensor for detecting rotational movement about a first axis;

second sensor for detecting rotational movement about a second axis perpendicular to the first axis; and

third sensor for detecting rotational movement about a third axis perpendicular to the first and second axes.

25

4. A six degree of freedom controller according to claim 1 wherein
the first conversion means comprises:

an upper platform fixed to the handle;

a plurality of sensors mounted to the upper platform;

30 a lower section provided on the shaft and having actuator means for activating the sensors; and

coupling means for rotationally mounting the upper platform to the lower section.

5. A six degree of freedom controller according to claim 1 wherein the second conversion means comprises:

first sensor for detecting linear movement along a first axis;

second sensor for detecting linear movement along a second axis perpendicular to the first axis; and

third sensor for detecting linear movement along a third axis perpendicular to the first and second axes.

6. A six degree of freedom controller according to claim 1 wherein the second conversion means comprises means for permitting rotational movement of the shaft and generating electrical signals indicative of the rotational movement.

7. A six degree of freedom controller according to claim 1 wherein the second conversion means comprises a sliding actuator plates assembly having a first plate movable along a first axis and a second plate movable along a second axis perpendicular to the first axis.

8. A six degree of freedom controller according to claim 1 wherein the second conversion means comprises:

a sliding actuator plates assembly having a first plate movable along a first axis and a second plate movable along a second axis perpendicular to the first axis; and

lower shaft means for facilitating movement of the shaft along a third axis perpendicular to the first and second axes.

9. A six degree of freedom controller according to claim 1 wherein the second conversion means comprises a movable platform.

10. A six degree of freedom controller according to claim 1 wherein the handle is spherical-shaped.

11. A six degree of freedom controller according to claim 1 wherein
5 the handle contains tactile feedback means for creating vibrations in the handle.

12. A six degree of freedom controller according to claim 1 further comprising electronic circuitry for interpreting the electrical signals generated by the first and second conversions means.

10

13. A method for translating six degrees of freedom motion from the physical world into corresponding electrical vectors using a controller, the controller having a base assembly, a handle, and a shaft, the shaft having one end operatively mounted to the handle and a second end operatively mounted
15 to the base assembly, the method comprising the following steps:

rotating the handle to generate electric vectors indicative of rotational movement about three orthogonal axes;

moving the handle relative to the base assembly to generate electric vectors indicative of linear movement along the three orthogonal axes;

20 selectively creating vibrations in the handle in accordance with the generated electric vectors.

1/10

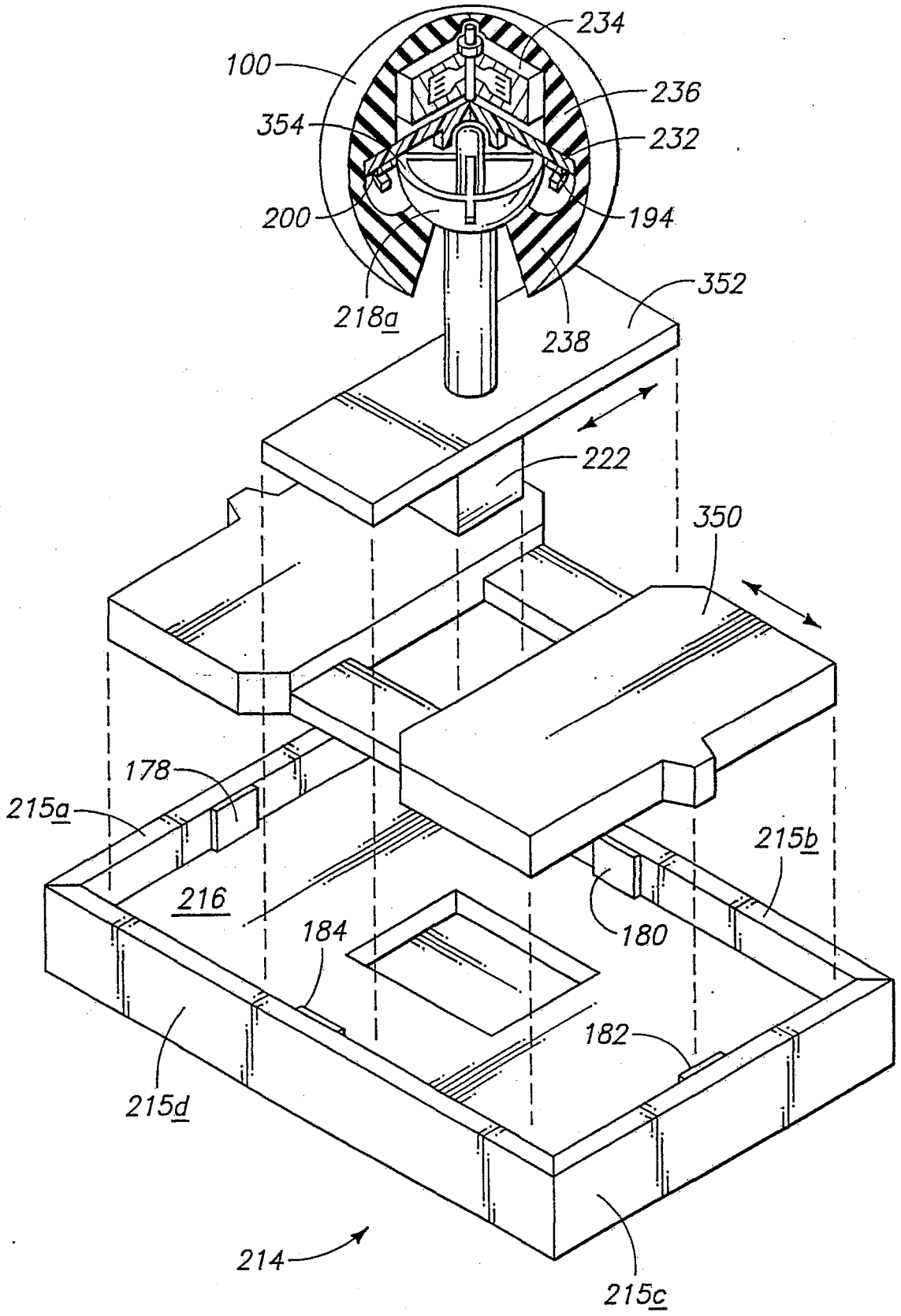
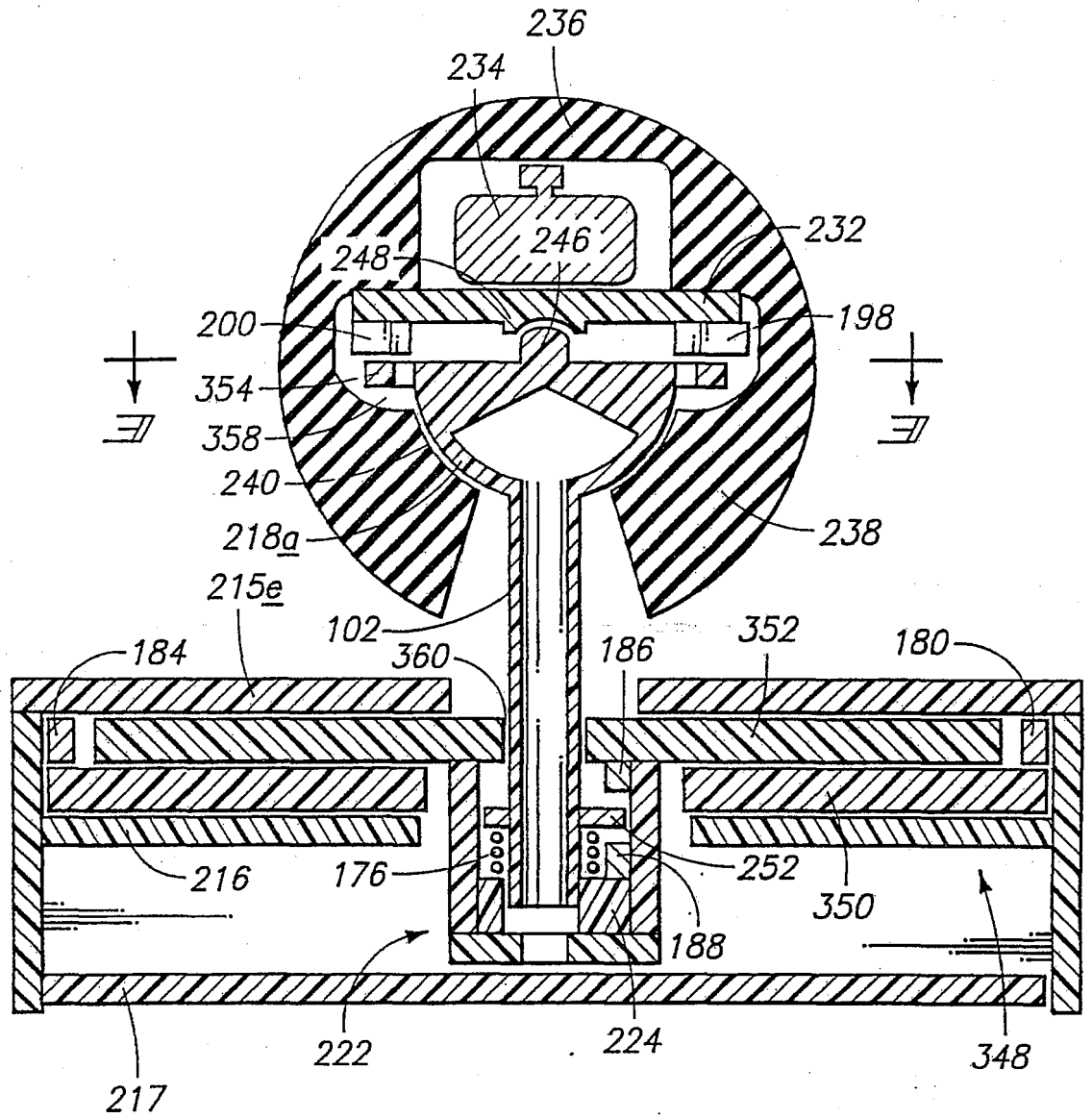

FIG. 1

2/10



3/10

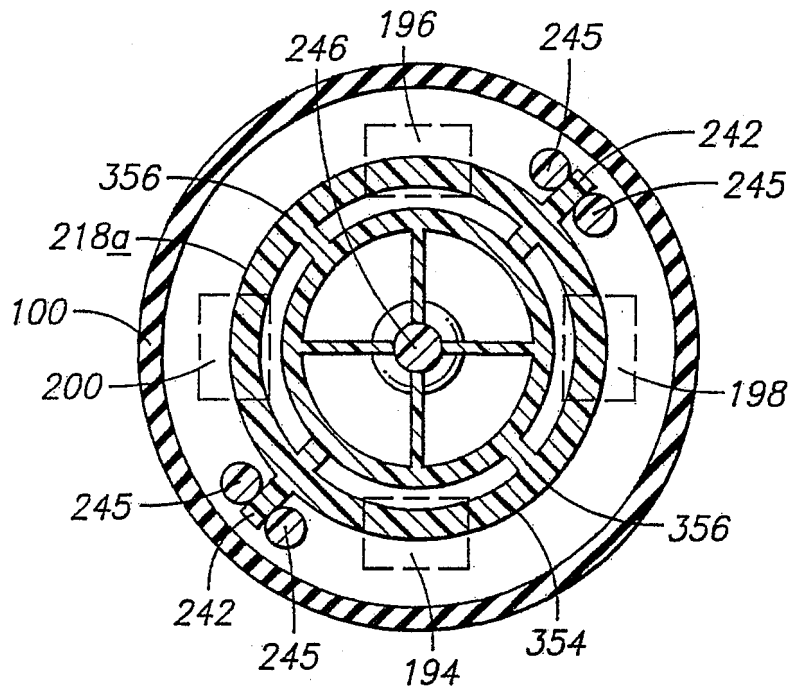

FIG. 3

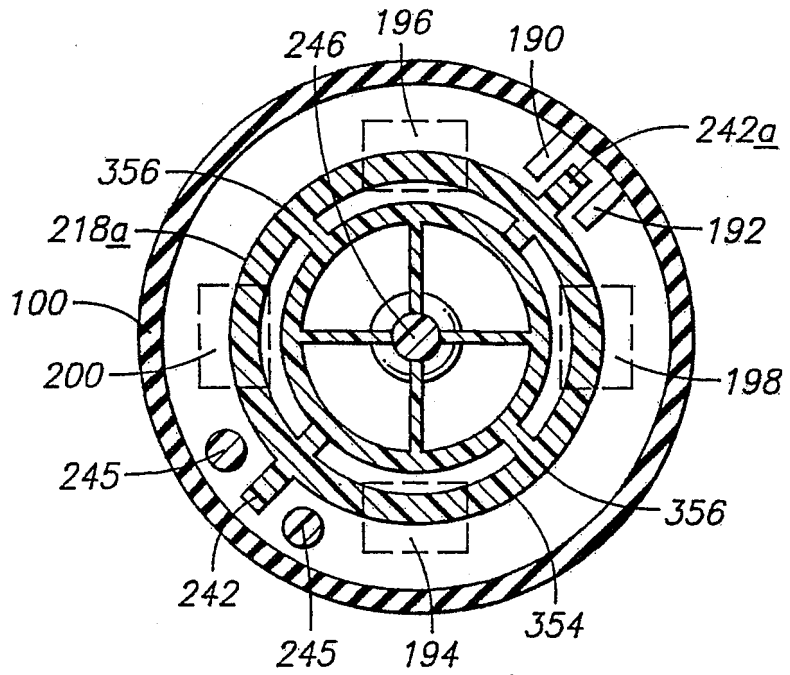
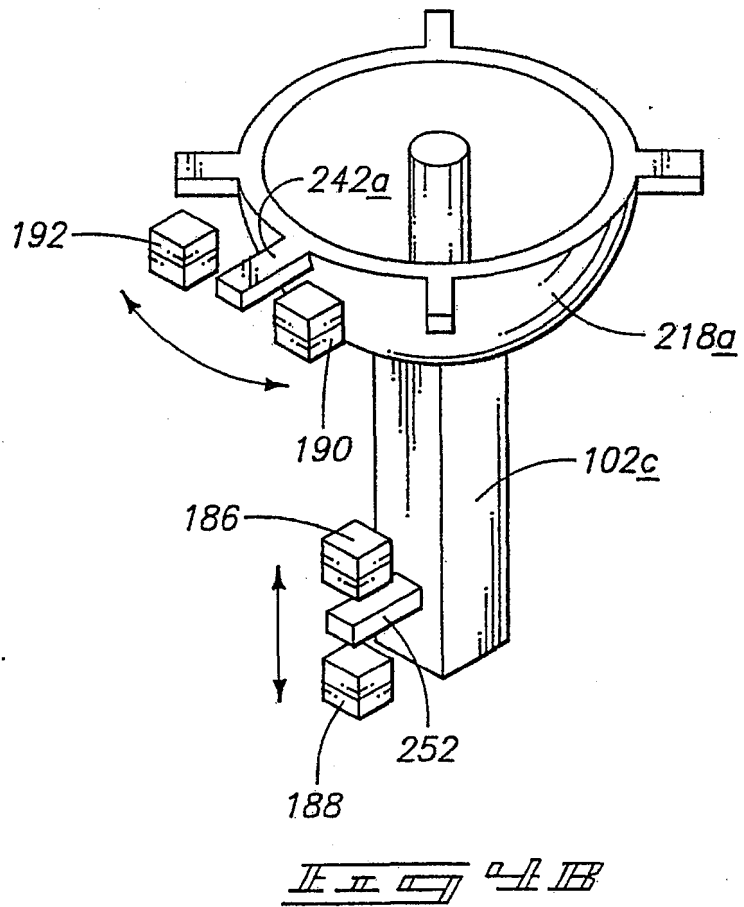
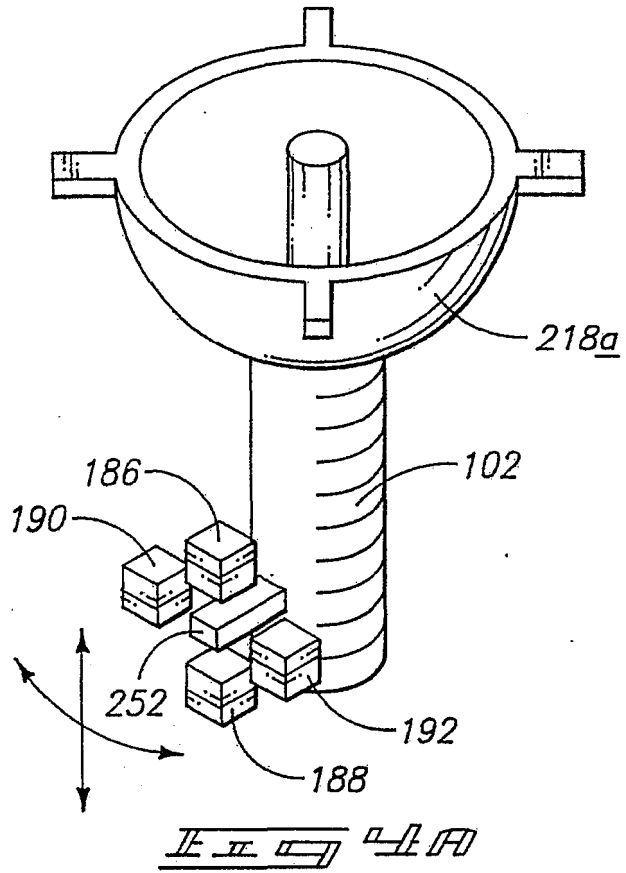
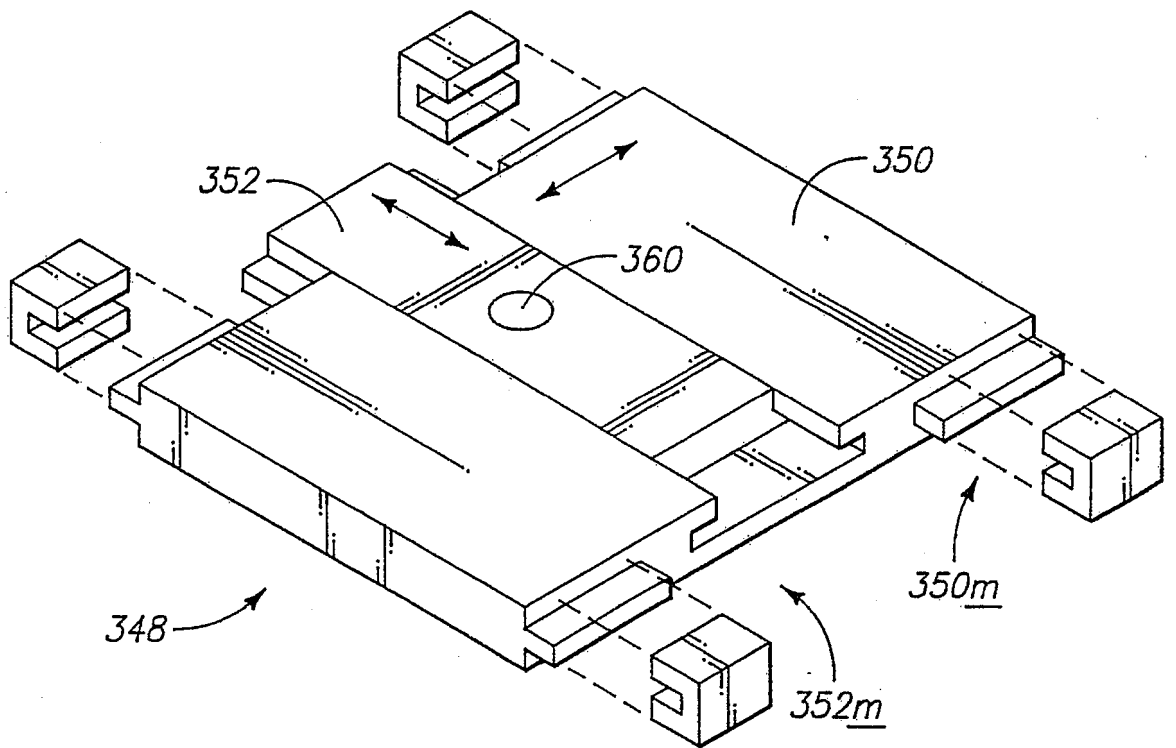

FIG. 4

4/10



5/10



II II SA

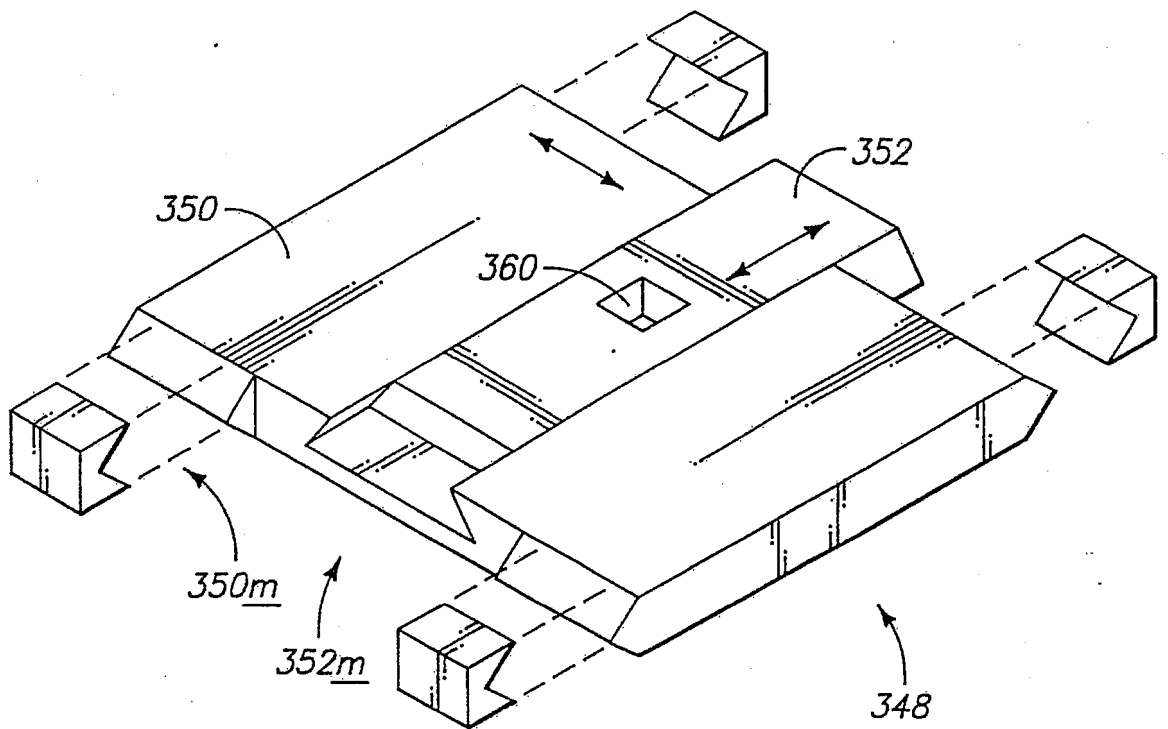

II II SB

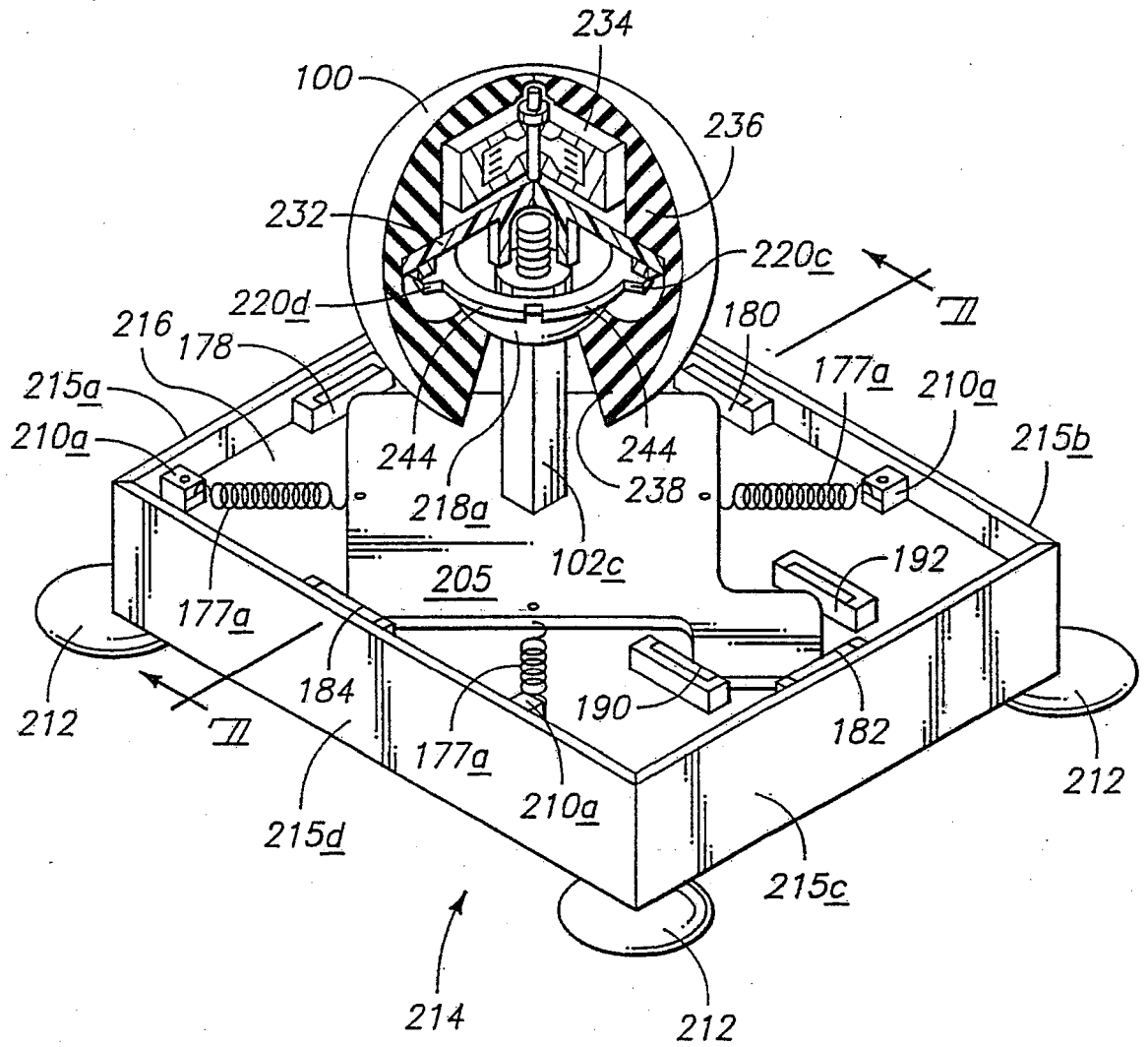

II II

7/10

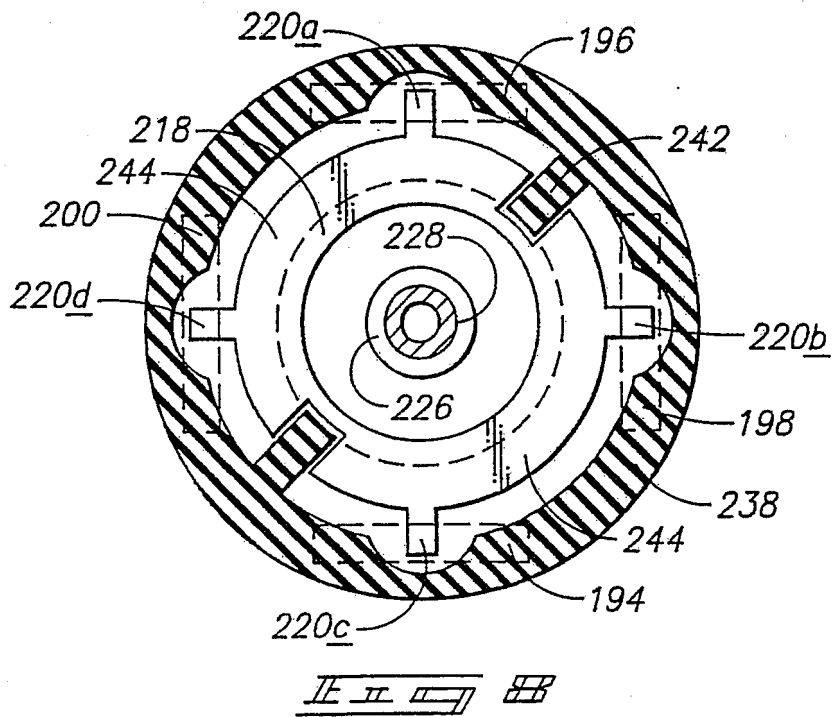
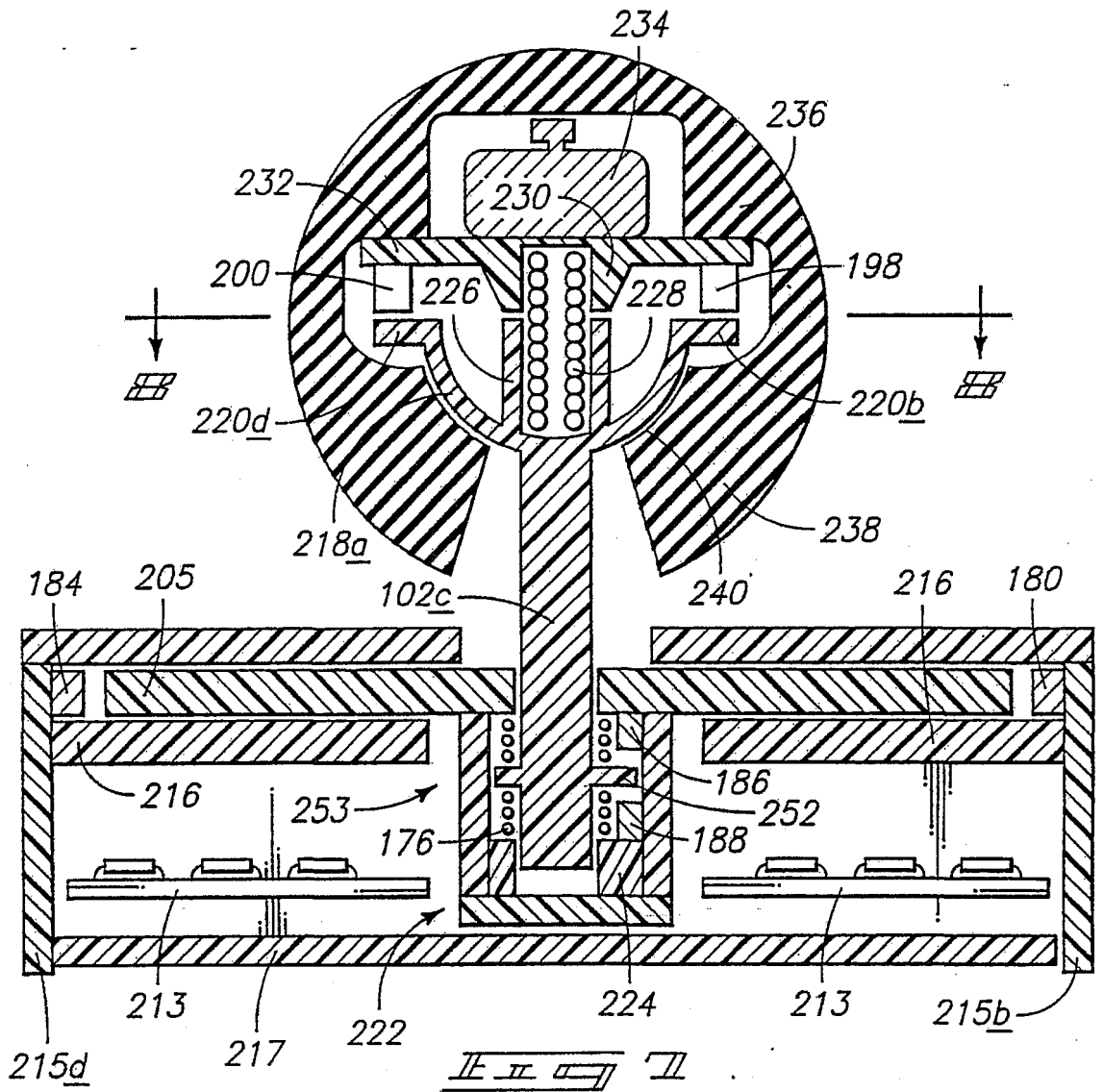

8/10

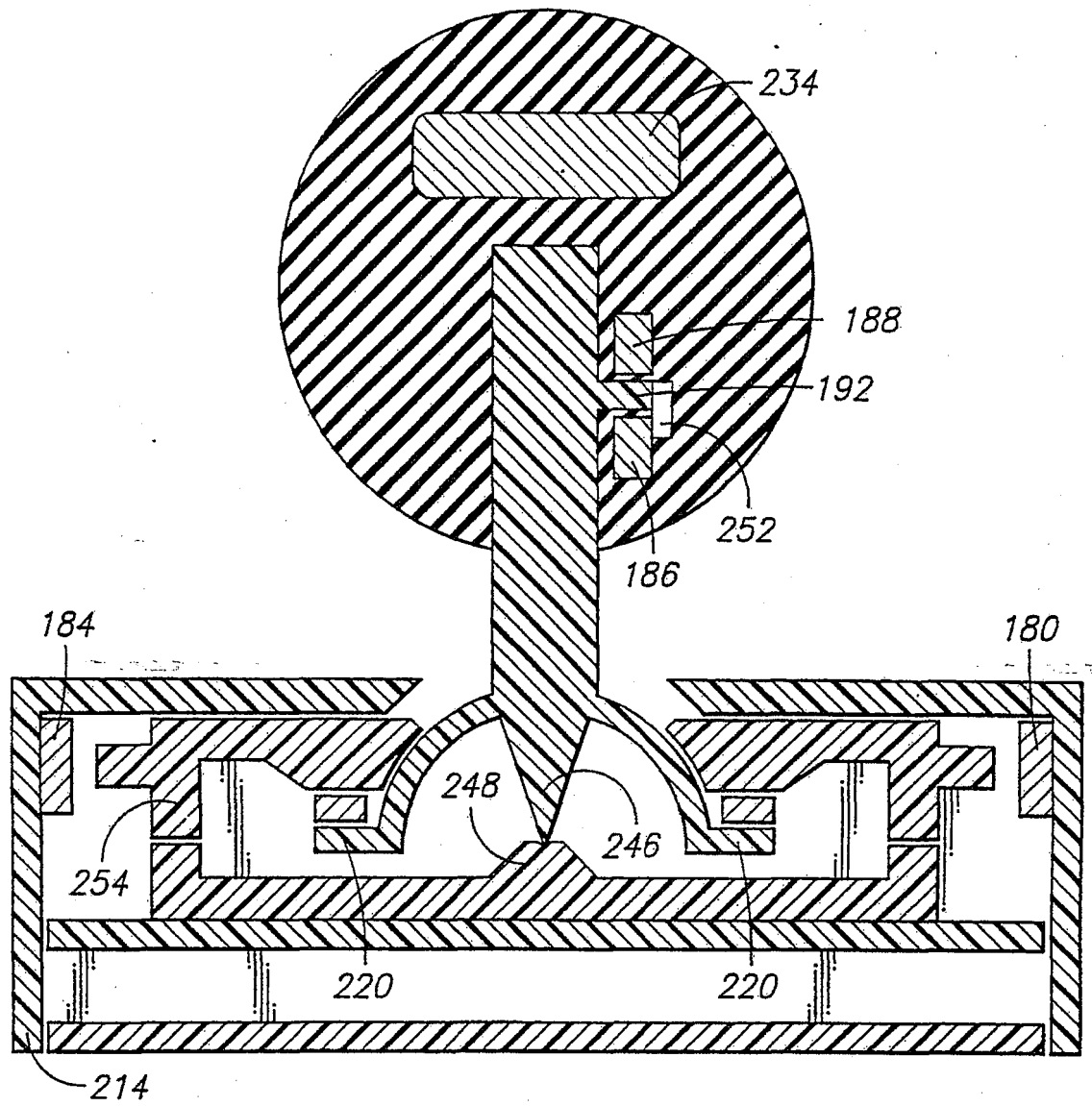

II II 4 9

9/10

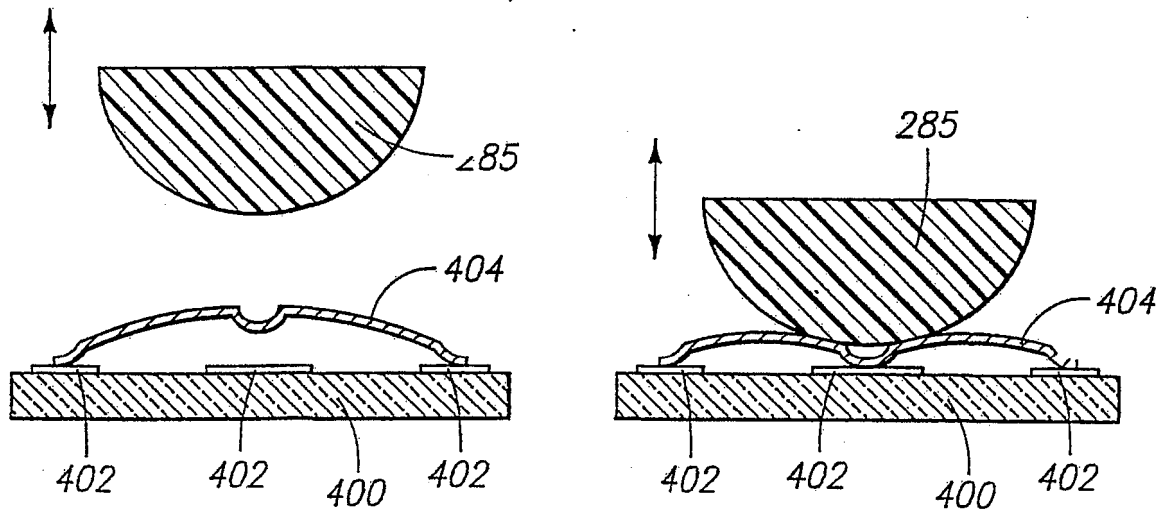

FIG. 1 FIG. 2

FIG. 3 FIG. 4

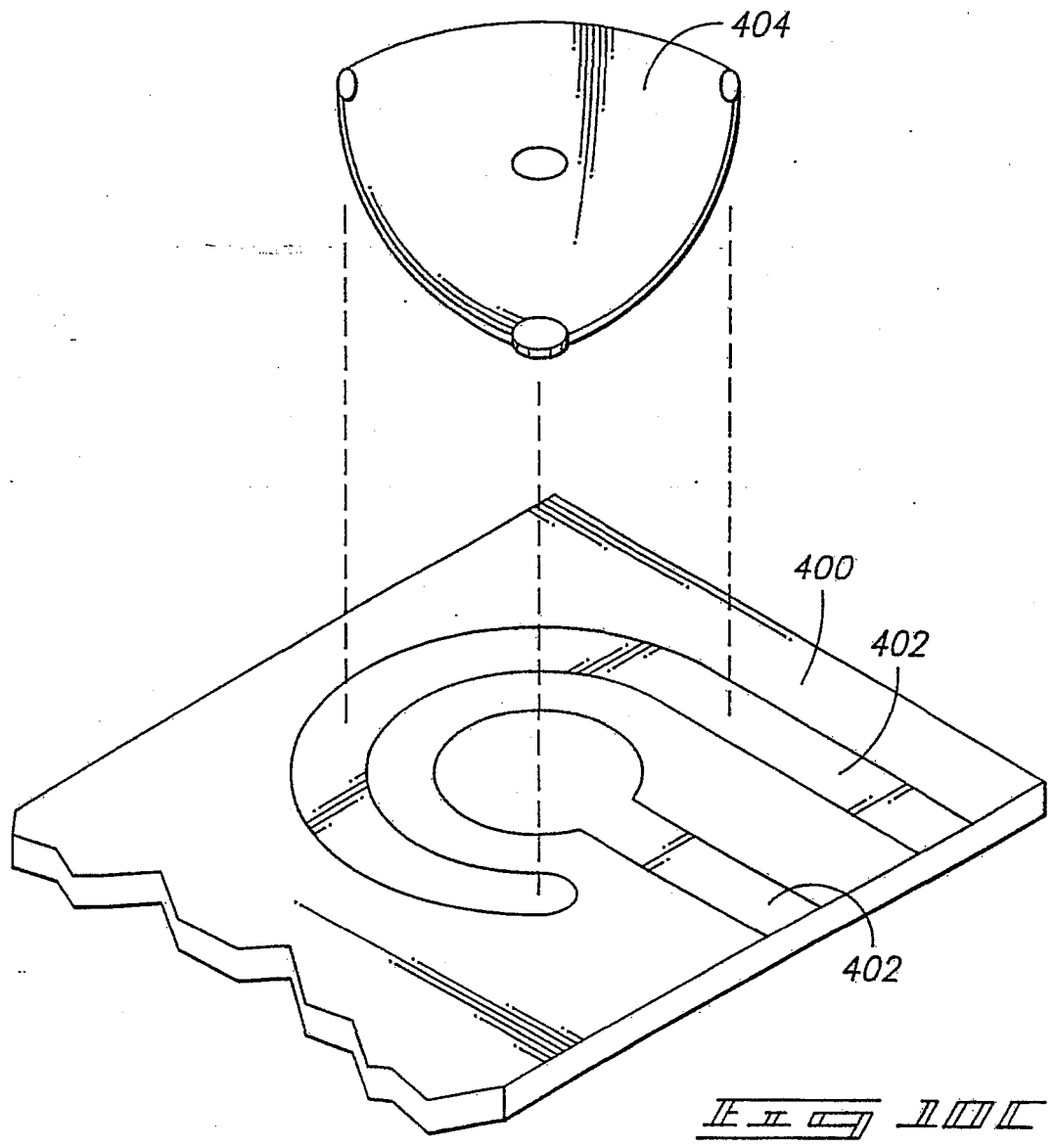
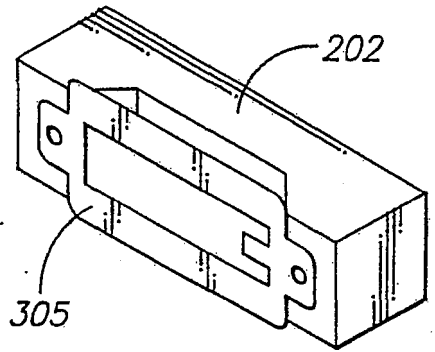
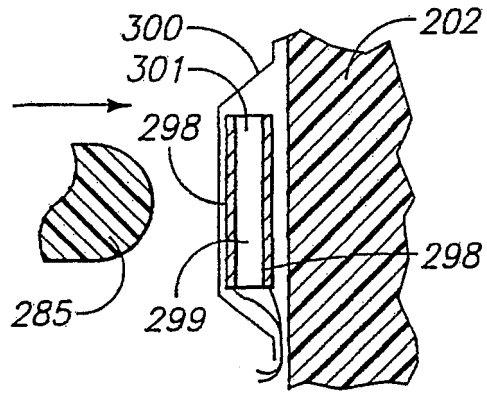
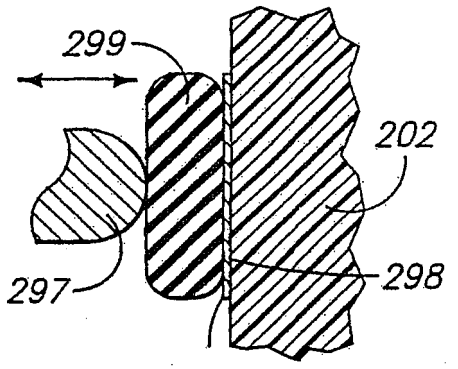
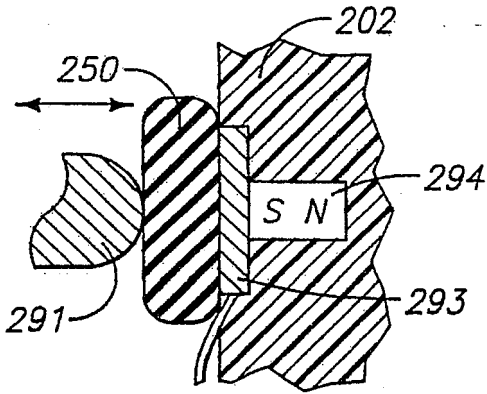
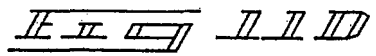
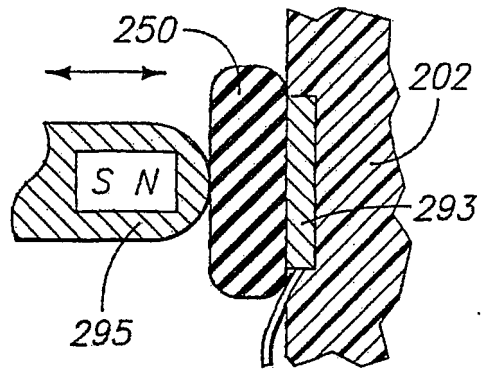
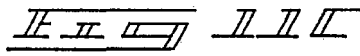
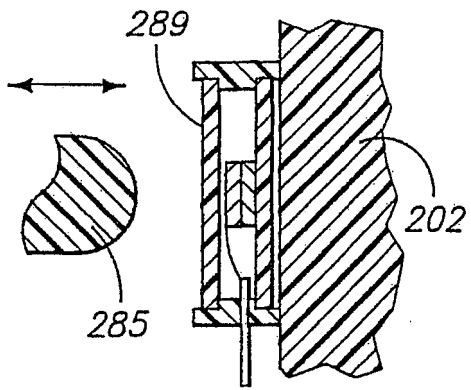
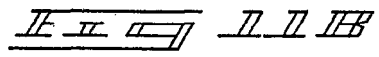
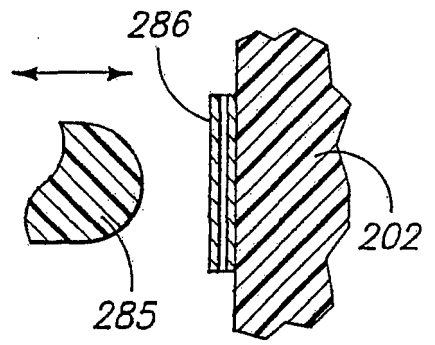
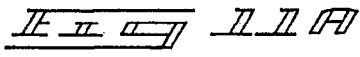
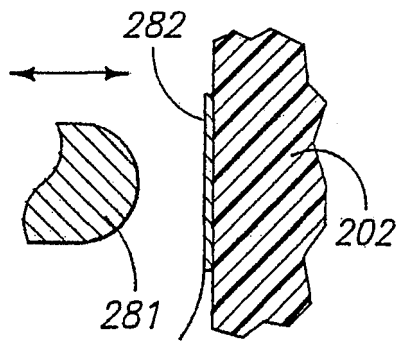

FIG. 5 FIG. 6



A. CLASSIFICATION OF SUBJECT MATTER

IPC5: G06G 9/04, H01H 25/00

According to International Patent Classification (IPC) or to both national classification and IPC

B. FIELDS SEARCHED

Minimum documentation searched (classification system followed by classification symbols)

IPC5: G05G, H01H

Documentation searched other than minimum documentation to the extent that such documents are included in the fields searched

Electronic data base consulted during the international search (name of data base and, where practicable, search terms used)

WPI, CLAIMS

C. DOCUMENTS CONSIDERED TO BE RELEVANT

Category*	Citation of document, with indication, where appropriate, of the relevant passages	Relevant to claim No.
X	US, A, 4555960 (MICHAEL KING), 3 December 1985 (03.12.85), see the whole document.	1-3,5-8,10,12
Y	--	4,9,11,13
X	GB, A, 2240614 (KAZAKHISKY GOSUDARSTVENNY UNIVERSITET), 7 August 1991 (07.08.91), see the whole document	1,2,5-8,12
Y	EP, A2, 0205726 (HALLABORATORY INC.), 30 December 1986 (30.12.86), abstract	4
	--	

Further documents are listed in the continuation of Box C.

See patent family annex.

* Special categories of cited documents:

- "A" document defining the general state of the art which is not considered to be of particular relevance
- "B" earlier document but published on or after the international filing date
- "L" document which may throw doubts on priority claim(s) or which is cited to establish the publication date of another citation or other special reason (as specified)
- "O" document referring to an oral disclosure, use, exhibition or other means
- "P" document published prior to the international filing date but later than the priority date claimed

"T" later document published after the international filing date or priority date and not in conflict with the application but cited to understand the principle or theory underlying the invention

"X" document of particular relevance: the claimed invention cannot be considered novel or cannot be considered to involve an inventive step when the document is taken alone

"Y" document of particular relevance: the claimed invention cannot be considered to involve an inventive step when the document is combined with one or more other such documents, such combination being obvious to a person skilled in the art

"&" document member of the same patent family

Date of the actual completion of the international search

Date of mailing of the international search report

14 June 1993

07. 07. 93

Name and mailing address of the ISA/

European Patent Office, P.B. 5818 Patentkan 2
NL-2280 HV Rijswijk
Tel. (+31-70) 340-2040, Tx. 31 651 spa nl,
Fax (+31-70) 340-3016

Authorized officer

Betil Nordenberg

C (Continuation). DOCUMENTS CONSIDERED TO BE RELEVANT

Category*	Citation of document, with indication, where appropriate, of the relevant passages	Relevant to claim No.
Y	GB, A, 2205941 (INTERNATIONAL BUSINESS MACHINES CORPORATION), 21 December 1988 (21.12.88), page 3, line 21 - line 27, figure 1 ---	9
Y	RESEARCH DISCLOSURES, Volume 283, November 1987, (USA), . . , "Joystick with Tactile Feedback" -----	11,13

Patent document cited in search report	Publication date	Patent family member(s)	Publication date
US-A- 4555960	03/12/85	CA-A- 1203738	29/04/86
GB-A- 2240614	07/08/91	DE-A- 4004760	22/08/91
EP-A2- 0205726	30/12/86	DE-A- 3685690	23/07/92
		JP-A- 61292734	23/12/86
GB-A- 2205941	21/12/88	EP-A- 0295368	21/12/88
		JP-B- 4077335	08/12/92
		JP-A- 63318623	27/12/88
		US-A- 5065146	12/11/91